

Knuffi®

The Soft Edge Warning and Bumper Guard

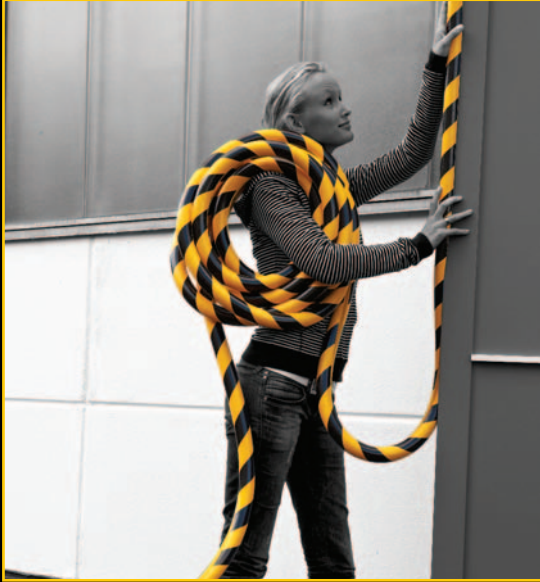

Knuffi® warning and protective bumper guards act as a buffer zone for people, machines, and objects; absorbing hard impacts and preventing injury and damage. Injury to personnel and downtime due to repairs can be a thing of the past. The black and yellow warning markings help to reduce accidents and highlight danger at edges, gaps and obstacles.

Knuffi® performs well in temperatures from -40°F to +212°F (-40°C to 100°C) making them versatile for use both indoors and outdoors, i.e., high traffic areas, hallways, corridors, machinery, forklifts, shelves, gates, and much more.

INFINITE SAFETY

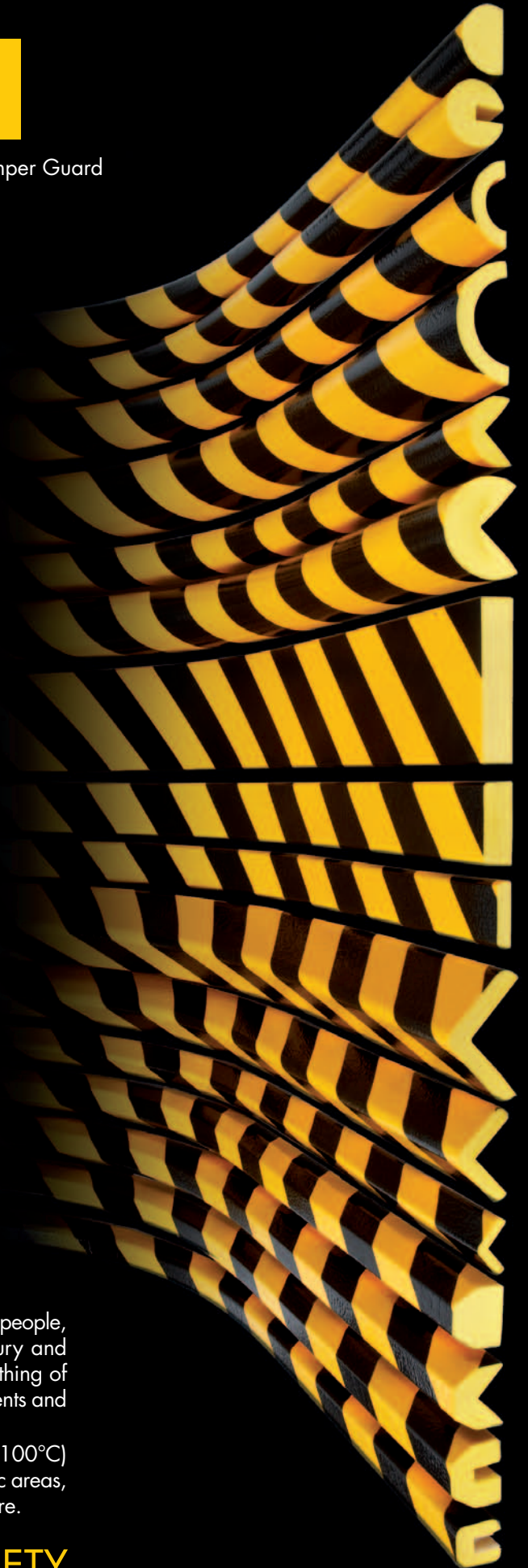

Technical Data

Profile Body: Recyclable Polyurethane foam, completely free of CFCs

Surface: Polyurethane foam colored by reverse printing and foamed in place so that no paint appears on the outside.

Adhesive: All types except "B" and "BB" are installed using light and ageing resistant, modified acrylic glue.

Adhesion: 21N/inch (25mm)

Temperature Range: -40°F to +212°F (-40°C to 100°C)

Fire Classification: B2 according to DIN 4102 and UL 94HB/10mm

Colors: bright yellow and black hatching as per BGV A8, red and white hatching as per BGV A8, solid black, solid white, fluorescent hatching, phosphorescent (glow in the dark) hatching

Standard Lengths: 3' 3-1/4" (1m), 16' 4-3/4" (5m) and up to 164'-0" (50m).

Installation: Simply adhere to clean, grease-free surface

Two dimensional protective corners



Protective corner type A

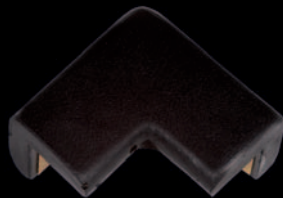

Protective corner type E

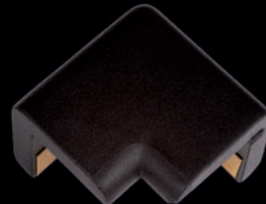

Protective corner type H

Three dimensional protective corners



Protective corner type A



Protective corner type E



Protective corner type H

Colors

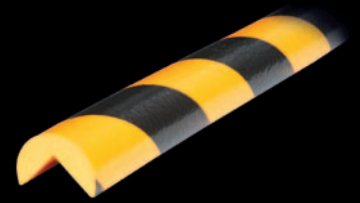

Black and Yellow



Red and White

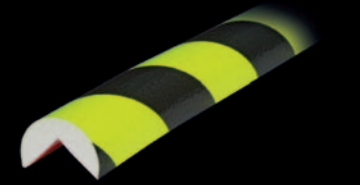

Fluorescent (in daylight)

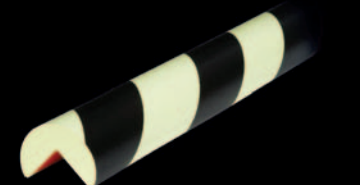

Phosphorescent
(glow in the dark)



White

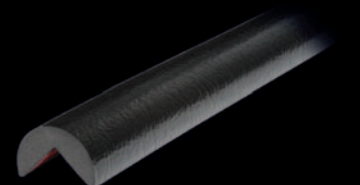

Black

Profiles

Corner Protection
Type A



Corner Protection A:
0.98" (25mm)

Corner Protection
Type A+



Corner Protection A+:
1.38" (35mm)

Corner Protection
Type BB

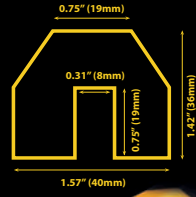

Edge Protection BB:
1.57"x1.42" (40x36mm)

Edge Protection
Type G

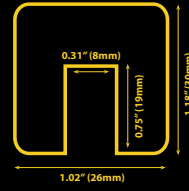

Edge Protection G:
1.02" (26mm)

Surface Protection
Type S



Surface Protection S:
2.95"x0.79" (75x20mm)

Piping Protection
Type R30



Piping Protection R30:
1.18" (30mm) inside radius

Piping Protection
Type R50

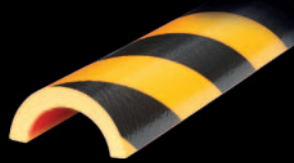
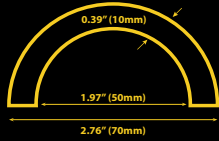

Piping Protection R50:
1.97" (50mm) inside radius

Edge Protection
Type B

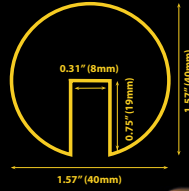

Edge Protection B:
1.57" (40mm)

Surface Protection
Type C

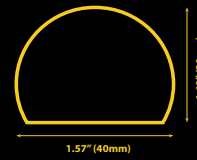

Surface Protection C:
1.57"x1.18" (40x30mm)

Surface Protection
Type CC

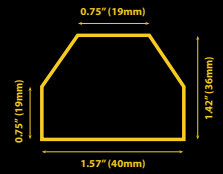

Surface Protection CC:
1.57"x1.42" (40x36mm)

Surface Protection
Type D



Surface Protection D:
1.97"x0.79" (50x20mm)

Surface Protection
Type F

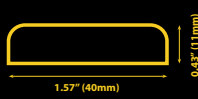

Surface Protection F:
1.57"x0.43" (40x11mm)

Corner Protection
Type AA

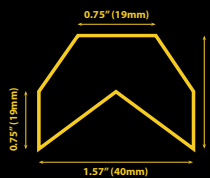

Corner Protection AA:
1.57"x1.42" (40x36mm)

Corner Protection
Type E



Corner Protection E:
0.75" (19mm)

Corner Protection
Type H

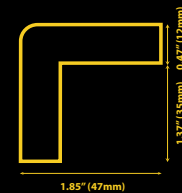

Corner Protection H:
1.37" (35mm)

Corner Protection
Type H+

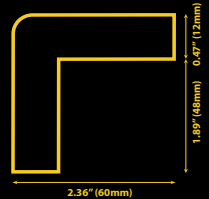

Corner Protection H+:
1.37" (35mm)

Profile dimensions may differ slightly from those stated.

Wall Protection Kit

The wall protection kit consists of a stainless steel backing and a Knuffi® warning and protective bumper guard. The stainless steel backing can easily be screwed onto uneven surfaces, providing solid protection for surfaces. Available in 3' 3-1/4" (1m) lengths, corner or surface protection, bright yellow and black hatching, or fluorescent (in day light) only.

Corner Protection

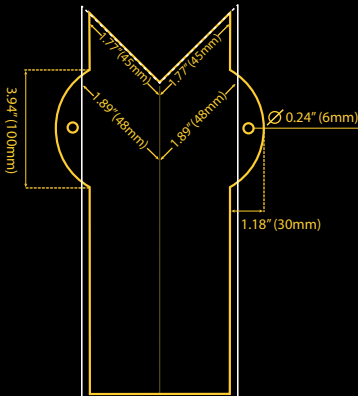

Thickness of Material 0.51" (13mm)
 ■ external protective profile
 ■ metal edging

Surface Protection

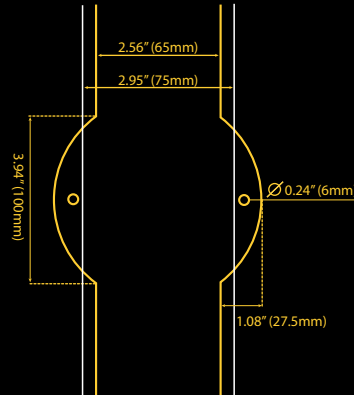

Thickness of Material 0.83" (21mm)
 ■ external protective profile
 ■ metal rails



Special Manufacturing Technique



Knuffi® are manufactured using a patented technique that prevents color deterioration under highly abrasive conditions. Knuffi® warning and protective bumper guards are manufactured from tough, flexible polyurethane foam and sheathed in polyurethane foil during the foam production. A reverse printing process, on the inward-facing side of the foil, allows the foil itself to protect the paint so that the warning colors remain in place even if heavy abrasion takes place. A light and ageing resistant, high performance adhesive is applied to the inside or back of the profiles.

